

# MPI TS150 | 150 mm Manual Probe System

For accurate and reliable DC/CV, RF and High Power measurements

## FEATURES / BENEFITS

### Universal Use

- Designed for wide variety of applications such as Device Characterization and Modeling, Wafer Level Reliability, Failure Analysis, IC Engineering, MEMS and High Power

### Ergonomic Design

- Unique puck controlled air bearing stage for quick single-handed operation
- Rigid platen accommodates up to 10 DC or 4 RF positioners
- Highly repeatable platen lift design with three discrete positions for contact, separation, and loading

### Upgradability

- Available with various chuck options and wide range of accessories such as DC/RF/mmW Micro-Positioners, Optics, microscopes and EMI shielded dark box to support various application requirements

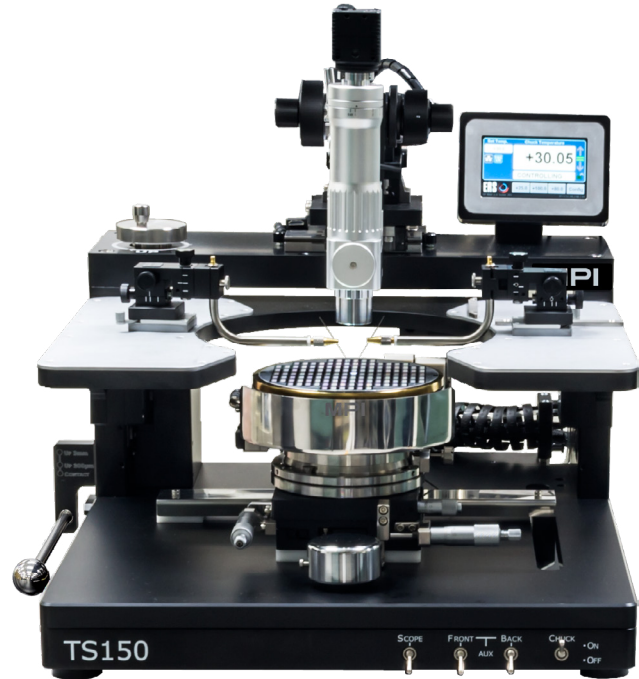

## SPECIFICATIONS

### Chuck XY Stage (Standard)

Total travel range	180 x 230 mm (7.1 x 9.1 in)
Fine-travel range	25 x 25 mm fine micrometer control
Fine-travel resolution	< 1.0 $\mu\text{m}$ (0.04 mils) @ 500 $\mu\text{m}/\text{rev}$
Planarity	< 10 $\mu\text{m}$
Theta travel (standard)	360°
Theta travel (fine)	$\pm 5.0^\circ$
Theta resolution	$7.5 \times 10^{-3}$ gradient
Movement	Puck controlled air bearing stage

### Optional XY Stage for TS150-ES

Planarity	< 10 $\mu\text{m}$ (0.4 mils)
Theta travel (standard)	Free movement up to 360°
Movement	Easy puck controlled air bearing stage for TS150-ES
Fine adjustment	N/A

**Manual Microscope Stage (Air Bearing)**

Movement range	25 x 25 mm (1 x 1 in)
Resolution	N/A
Scope lift	Manual, tilt-back
Movement	Air bearing control, fixed by vacuum

**Manual Microscope Stage (Linear)**

Movement range	50 x 50 mm (2 x 2 in)
Resolution	< 5µm (0.2 mils)
Scope lift	Manual, tilt-back or vertical (depending on microscope type)
Movement	Independently controlled X and Y movement with locking screws

## PROBE PLATEN

**Specifications**

Material	Nickel plated steel
Dimensions	See drawing
Chuck top to platen top	Min. 28 mm
Max. No of MicroPositioners	10 DC and 4 RF
Platen lift control	3 positions - contact (0), separation (300 µm), and loading (3 mm)
Platen Z-height movement	High resolution screw for fine control
Z-height adjustment range	Max. 20 mm (0.8 in)
Separation repeatability	< 1 µm (0.04 mils) by „automated“ control
RF MicroPositioner mounting	Magnetic with guided rail
DC MicroPositioner mounting	Magnetic
300 °C thermal isolation	Depends on chuck configuration

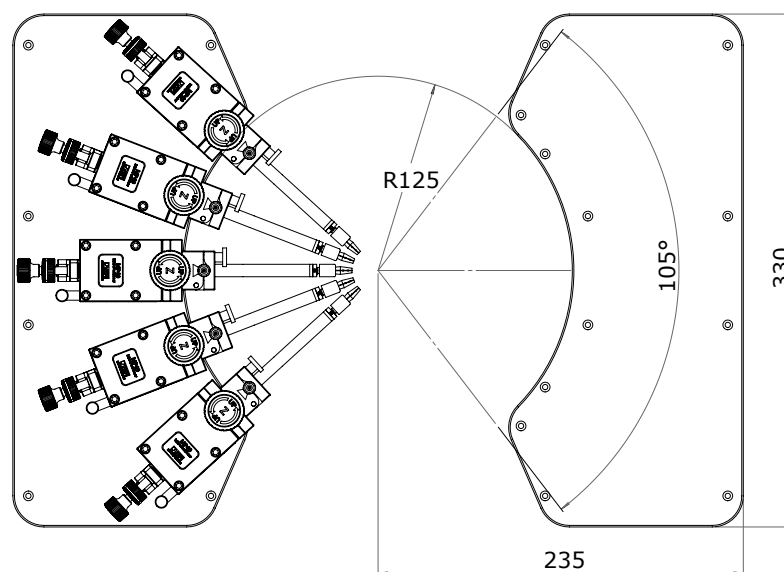

Universal probe platen design for up to 10 DC MicroPositioners

## NON-THERMAL CHUCKS

### Standard Wafer Chucks

Connectivity 1	Coaxial chuck: Coax BNC (f)
Connectivity 2	Triaxial chuck: Kelvin Triax (f)
Diameter	160 mm
Material	Stainless steel
Chuck surface	Planar with centric engraved vacuum grooves
Vacuum grooves sections (diameter)	3, 27, 45, 69, 93, 117, 141 mm
Vacuum actuation	Multizone control - All connected in meander shape, center hole in 3 mm diameter
Supported DUT sizes	Single DUTs down to 4 x 4 mm size or wafers 50 mm (2 in) thru 150 mm (6 in)*
Surface planarity	$\leq \pm 5 \mu\text{m}$
Rigidity	$< 15 \mu\text{m} / 10 \text{ N @edge}$

\*Single DUT testing requires higher vacuum conditions dependent upon testing application.

### RF Wafer Chuck

Connectivity	Coax BNC (f)
Diameter	150 mm with 2 integrated AUX areas
Material	Nickel plated aluminum (flat with 0.5 mm holes)
Chuck surface	Planar with 0.5 mm diameter holes in centric sections
Vacuum holes sections (diameter)	3, 27, 45, 69, 93, 117, 141 mm
Vacuum actuation	Manual switch between Center (4 holes), 50, 100, 150 mm (2, 4, 6 in)
Supported DUT sizes	Single DUTs down to 4 x 4 mm size or wafers 50 mm (2 in) thru 150 mm (6 in)*
Surface planarity	$\leq \pm 5 \mu\text{m}$
Rigidity	$< 15 \mu\text{m} / 10 \text{ N @edge}$

\*Single DUT testing requires higher vacuum conditions dependent upon testing application.

### Auxiliary Chuck

Quantity	2 AUX chucks
Position	Integrated to rear side of main chuck
Substrate size (W x L)	Max. 25 x 25 mm (1 x 1 in)
Material	Ceramic, RF absorbing material for accurate calibration
Surface planarity	$\leq \pm 5 \mu\text{m}$
Vacuum control	Controlled independently, separate from chucks

### Electrical Specification (Coax)

Operation voltage	In accordance with EC 61010, certificates for higher voltages available upon request
Maximum voltage between chuck and GND	500 V DC
Isolation	$> 2 \text{ G}\Omega$

### Electrical Specification (Triax)

	Standard Chuck (10 V)
Chuck isolation	$> 100 \text{ G}\Omega$
Force to guard	$> 100 \text{ G}\Omega$
Guard to shield	$> 10 \text{ G}\Omega$
Force to shield	$> 50 \text{ G}\Omega$

## THERMAL CHUCKS

### Specifications of MPI ERS Integrated Technology

	35 °C to 150 °C	20 °C to 200 °C	20 °C to 200 °C	20 °C to 300 °C
Connectivity	Coax BNC (f)	Coax BNC (f)	Kelvin Triax (f)	Single Triax (f)
Temperature control method	Cooling air / Resistance heater	Cooling air / Resistance heater	Cooling air / Resistance heater	Cooling air / Resistance heater
Coolant	Air (user supplied)	Air (user supplied)	Air (user supplied)	Air (user supplied)
Smallest temperature selection step	0.1 °C	0.1 °C	0.1 °C	0.1 °C
Chuck temperature display resolution	0.1 °C	0.01 °C	0.01 °C	0.01 °C
External touchscreen display operation	N/A	Yes	Yes	Yes
Temperature stability	±0.5 °C	±0.08 °C	±0.08 °C	±0.08 °C
Temperature accuracy	±1 °C	0.1 °C	0.1 °C	0.1 °C
Control method	DC/PID	Low noise DC/PID	Low noise DC/PID	Low noise DC/PID
Interfaces	RS232C	RS232C	RS232C	RS232C
Chuck surface plating	Nickel plated with pinhole surface	Nickel plated with pinhole surface	Nickel plated with pinhole surface	Gold plated with pinhole surface
Temperature sensor	Pt100 1/3DIN	Pt100 1/3DIN, 4-line wired	Pt100 1/3DIN, 4-line wired	Pt100 1/3DIN, 4-line wired
Temperature uniformity	< ±1 °C	< ±0.5 °C	< ±0.5 °C	< ±0.5 °C at 20 to 200 °C < ±1.0 °C at > 200 °C
Surface flatness and base parallelism	< ±15 µm	< ±10 µm	< ±10 µm	< ±10 µm
Heating and cooling rates	35 to 150 °C < 10 min 150 to 35 °C < 15 min	20 to 200 °C < 15 min 200 to 20 °C < 15 min	20 to 200 °C < 20 min 200 to 20 °C < 20 min	20 to 300 °C < 15 min 300 to 20 °C < 20 min
Electrical isolation Coax BNC (f)	> 0.5 T Ω at 25 °C	> 10 T Ω at 25 °C > 300 G Ω at 200 °C	N/A	N/A
Leakage @ 10 V Kelvin Triax (f)	N/A	N/A	< 15 fA at 25 °C < 30 fA at 200 °C	< 15 fA at 25 °C < 50 fA at 300 °C
Capacitance	< 750 pF	< 900 pF	N/A	N/A
Maximum voltage between chuck top and GND	500 V DC	500 V DC	500 V DC	500 V DC

## FACILITY REQUIREMENTS

### Thermal Chuck Electrical Supply

Electrical primary connection	100 to 240 VAC auto switch
Frequency	50 Hz / 60 Hz

### Compressed Air Supply

Operating pressure	6.0 bar (0.6 MPa, 87 psi) at specified flow rate
CDA dew point	≤ 0 °C

### Controller Dimensions / Power and Air Consumption

System Type	W x D x H (mm)	Weight (kg)	Power Cons. (VA)	max. Air Flow (l/min)
35 to 150 °C - Coax BNC (f)	300 x 265 x 135	10	500	150
20 to 200 °C - Coax BNC (f)	300 x 360 x 135	12	700	200
20 to 200 °C - Kelvin Triax (f)	300 x 360 x 135	12	700	200
20 to 300 °C - Single Triax (f)	300 x 360 x 135	12	700	200

**General Probe System**

Power	100-240 V AC nominal; 50/60 Hz for optical accessories* only
Vacuum	-0.5 bar (for single DUT) / -0.3 bar (for wafers)
Compressed air	6.0 bar

\*e.g. microscope illumination, CCD cameras, monitors.

**REGULATORY COMPLIANCE**

- Certification: CE

**WARRANTY**

- Warranty\*: 12 months
- Extended service contract: contact MPI Corporation for more information

**PHYSICAL DIMENSIONS****Station Platform with Bridge\***

Dimensions (W x D x H)	470 x 505 x 635 mm (18.5 x 19.9 x 25.0 in)
Weight	~60 kg (132 lb.)

\*Station accessories, such as different microscopes, cameras, or laser cutters, may change the total height.

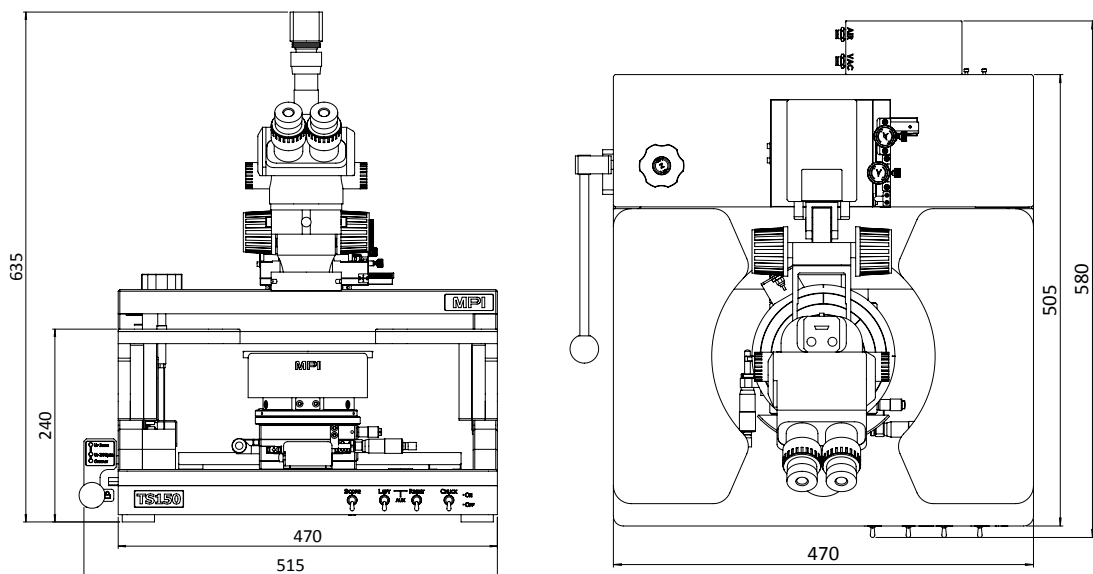

\*See MPI Corporation's Terms and Conditions of Sale for more details.

Direct contact:  
 Asia region: ast-asia@mpi-corporation.com  
 EMEA region: ast-europe@mpi-corporation.com  
 America region: ast-americas@mpi-corporation.com

MPI global presence: for your local support, please find the right contact here:  
[www.mpi-corporation.com/ast/support/local-support-worldwide](http://www.mpi-corporation.com/ast/support/local-support-worldwide)

**MPI Global Presence**